

IMPACK ProMotion

Continuous motion high speed side sealer

PackagingIntelligence



IMPACT ProMotion

Continuous motion high speed side sealer

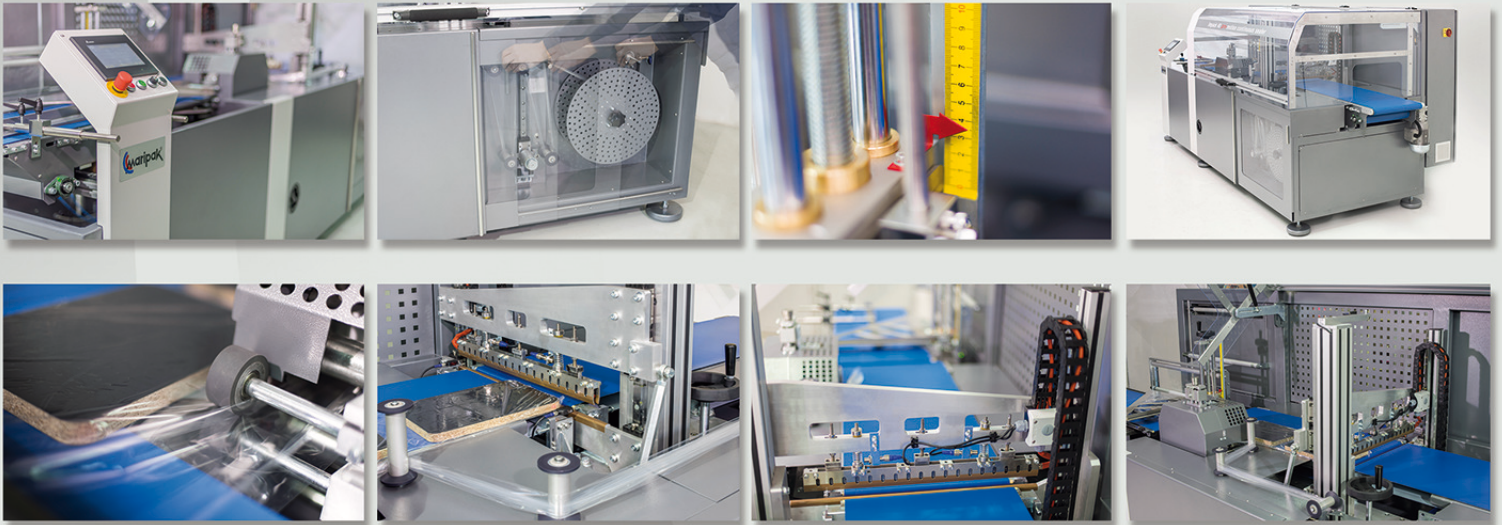

Technical specifications

	Impact ProMotion 20	Impact ProMotion 40	Impact ProMotion 60	Impact ProMotion 80
Sealer Opening: 250mm	Max. Packaging Sizes (WxLxH): 170 x Unlimited x 250mm	370 x Unlimited x 250mm	570 x Unlimited x 250mm	770 x Unlimited x 250mm
Max. Speed: 30mt/min	Cross Sealer Length: 400mm	540mm	730mm	930mm
Max. Cycle: 80 packs/min*	Conveyor Belt Width: 200mm	400mm	600mm	800mm
Max. Roll Diameter: Ø 270mm	Max. Film Width: 700mm	700mm	1000mm	1000mm
Working Height: 860mm Optionally Higher (+50mm)	Installed Power (50-60Hz): 400V, 3x7 Ampere, 3 Phase	400V, 3x7 Ampere, 3 Phase	400V, 3x7 Ampere, 3 Phase	400V, 3x9 Ampere, 3Phase
Film Types: 7-40 µm PO, PP " V " Knife 40-60 µm PE, OPP " W " Knife	Consumption (Max. / Avarege): 7 kW / 5 kW	7 kW / 5 kW	7 kW / 5 kW	9 kW / 6 kW
Color: Mixed grey + RAL7010 + RAL7015	Dimens. (AxBxC): 1190 x 3255 x 1885mm	1400 x 3255 x 1885mm	1855 x 3755 x 1930mm	1935 x 3755 x 1930mm
	Palletized Size (AxBxC): 1500 x 3450 x 1600mm	1500 x 3400 x 1600mm	2000 x 3950 x 1650mm	2200 x 3950 x 1650mm
	Weight (Net / Gross): 700 kg / 790 kg	980 kg / 1010 kg	1090 kg / 1250 kg	1140 kg / 1320 kg

* Real working speed depends on the product dimensions and the film type.

* Minimum packaging width for Impact ProMotion 60 and Impact ProMotion 80 series: 250mm

Advantages:

- Nonstop operation with continuous motion system
- Dual axis servo motor driven cross sealing
- High precision and consistency with cross and side seal
- Packaging with no length limit
- Control of film quantity on the 4 sides of packages for saving results
- Minimized layout requirement by compact single-chassis design
- Reduced energy & increased safety

Features:

- Touch control panel with color screen
- Encoder controlled speed & length aware synchronization
- Easy format change for different package sizes
- Regular or finger pitch conveyors for feeding can be applied
- Ergonomic operator panel with most useful hard buttons
- Up-to-date safety electric and mechanic measures of CE directives
- Cross and continuous knives with PID controlled heaters
- Automatic film dispenser with tension control
- Photocell controlled package distance positioned feeding
- Automatic length detection option

Sealing:

- Film sealing under no distortion with non stop and tight operation
- Up to 15% advantage in film consumption
- Film tension releasing on the cross-sealing point
- Trim winder is designed to control very thin films without breakage
- Height adjustable cross sealer (Optional motorized)
- Adjustable "Central Sealing" for varied package height applications

Flexibility:

- Native languages can be applied
- Recipe application with different package dimensions
- Warning messages for potential emergency cases
- "Navigation Control" for actual throughput and estimated packs/ time units

Optional:

- Double seal feature on cross sealer for high thickness or PE material
- Control of external infeed conveyor through operator panel
- Vertical photocell to detect thin packages
- Printed marker registered film detection & application

Quality:

- ISO 9001 quality standard with the relevant norm's confirmations
- CE marking
- One year warranty on non-wearable parts
- Manufacturer's guarantee for spare part & after sales support

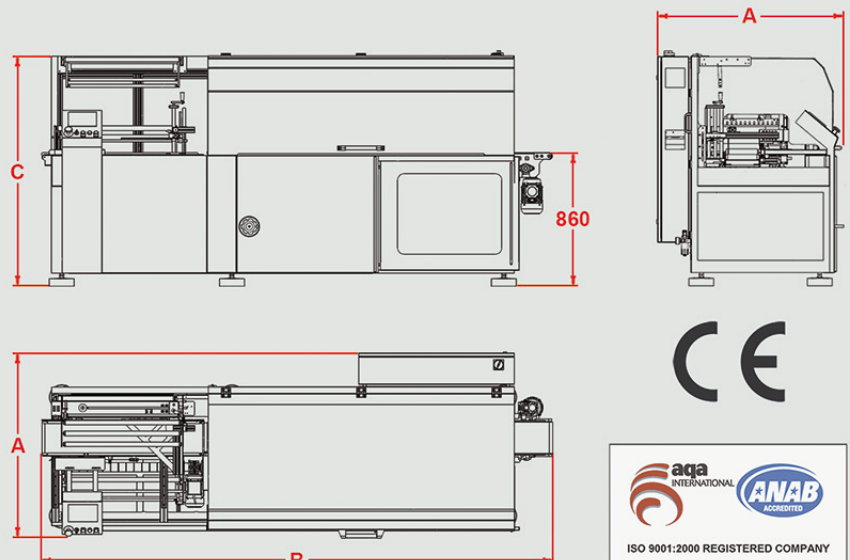

R5 EN