

TT60 Random Packer

4 Sides Sealed, Fit-to-size Packaging Machine

PackagingIntelligence



eCOMMERCE Packaging Solutions



TT60 Random Packer

4 Sides Sealed, Fit-to-size Packaging Machine

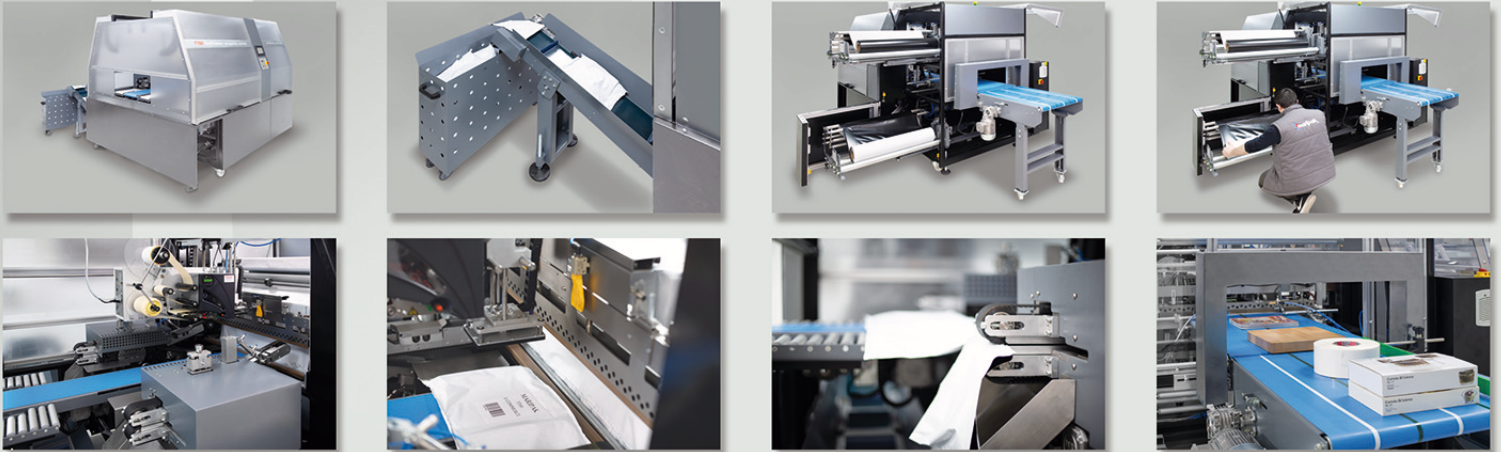

Technical Specifications

Max. Packaging Sizes (WxLxH): 600 x Unlimited x 150mm (24 x Unlimited x 6")	Min. Package Sizes (WxLxH): 230 x Unlimited x 10mm (9 x Unlimited x 0.4")	Air (Requirement / Consumption): 6-7 Bar, 4-5 liters / cycle
Max. Cycle: Random mode: 9 ppm, Fixed size mode: 20 ppm*	Max. Film Width: 900mm (35")	Installed Power: 50-60Hz, 3 x 220V, 17 Ampere, 3 Phase
Conveyor Speed: 30 mt/min (780 ipm) (adjustable)	Film Thickness (Hot knife / Ops.cold cutv syst): 10-50 micron, / 50-125 micron	Consumption (Max. / Avarege): 12 kW / 6 kW
Sealer Length: 950mm (37")	Film Types: POF, PE, OPP, CPP, PP	Dimensions (AxBxC): 2624 x 3477 x 2235mm (103 x 137 x 88")
Working Height (D): 950mm (37")	Max. Roll Diameter: 300mm standard (adjustable) (12")	Palletized Size (AxBxC): 2230 x 2900 x 2400mm (88 x 114 x 94") plus conveyors
Conveyor Belt Width (E): 600mm (24")	Color: Gray mixed + RAL7010 + RAL7015	Weight (Net / Gross): 2100 kg / 2290 kg (4630 lb / 5049 lb)

* Depending on the film type, the thickness may change

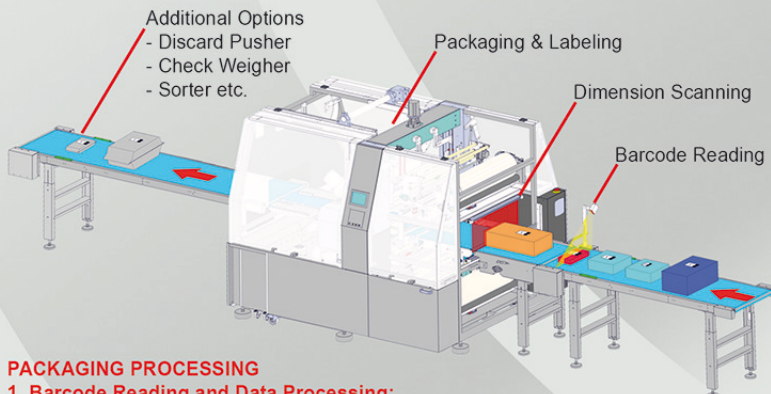

PACKAGING PROCESSING

1. Barcode Reading and Data Processing:

- Barcode on the products are scanned by a barcode scanner
- The data scanned is processed and matched with the right shipping address
- The shipping address info is sent to the labeling unit

2. Dimension Scanner and Packaging:

- Dimension of each product is measured by a dimension light barrier sensor
- Twin side sealers adapt themselves accordingly to the product size and pack the product

3. Labeling Unit:

- The labeling system prints the label
- The label is applied on the product with a height adaptive touch-on vertical tamping arm

4. Additional Options:

- Secondary control with a barcode scanner that is integrated with a discard pusher system
- Check weigher and industrial PC control for different shipment options
- Sorting system of the packed products according to the destination

Features:

- Servo driven motor control of twin side sealers vertically and horizontally
- Scrap collection conveyors on both sides
- Every package size is individually scanned to reduce the cost of transport
- Centered and off-centered feeding of packages are also possible
- Easy film roll slides for top and bottom rolls for nesting new film rolls
- Touch control panel with color screen
- Encoder controlled speed & length aware synchronization
- Up-to-date safety electric and mechanic measures of CE directives
- Cross and side sealers with PID controlled heaters
- Automatic film transport system with tension control
- Easy film drive system to enable light packs to go through the sealing area
- Automatic length detection system

Advantages:

- Randomly loaded different sized packages can be wrapped automatically
- E-commerce & automatic mailing automation system with labeling
- Integration into the company server systems to upload daily shipment information
- Minimized package sizes with package-sensitive dimension control
- Minimum operator, maximum shipment quantity with high level precision

Flexibility:

- Native languages can be applied
- Warning messages for potential emergency cases
- "Navigation Control" for actual throughput and estimated packs/time units

Quality:

- ISO 9001 and CE certified
- One year warranty on non-wearable parts
- Manufacturer's guarantee for spare part & after sales support

